

STRENGTH AND BEHAVIOUR OF METAL TIES IN 2-WYTHER MASONRY WALLS

M.A. Hatzinikolas
J. Longworth
J. Warwaruk

STRENGTH AND BEHAVIOUR OF METAL TIES IN 2-WYTHE MASONRY WALLS

ABSTRACT

Tests were performed on masonry specimens consisting of brick facing and concrete block back-up elements interconnected by eight different commercially available lateral ties. Tests were conducted using specially designed equipment capable of subjecting the ties to compression or tension forces. Failure loads are presented for the various tie types. An analytical approach, presented for the determination of failure loads, compares favorably with test results. Values of allowable load are proposed for the types of ties tested.

INTRODUCTION

Two-wythe walls provide resistance to rain penetration and suitable space for placing insulation. There is a trend to increased cavity width for thicker insulation to provide greater energy efficiency. A common cavity wall system used in Canada consists of a 100 mm thick brick facing, a cavity, and a masonry or other structural back-up element. Lateral ties between the brick facing and the back-up element create an interaction between the two in resisting lateral loads applied to the brick facing.

This paper presents the results of a study of the strength and behaviour of lateral ties and the effect of ties on the composite action of typical

cavity walls used in Canadian construction. The extensive experimental program involved specimens constructed with different types of backup elements and various types of ties currently employed. A new apparatus was developed for testing ties. Variables included in the study were mortar type, cavity width, type of back-up element, configuration and physical properties of ties.

GENERAL

Various types of ties and their location within a cavity wall system are shown in Figure 1. The most common tie consists of two or more horizontal rods connected by cross rods to form a ladder, a truss, or other shapes. Some ties allow for adjustment in the misalignment of mortar joints in the outer and inner wythes.

The current design code in Canada, (CSA-S304-M78), does not allow sharing of lateral loads between the wythes. All loads must be resisted by the backup system. In addition, lateral deflection is limited, with $span/360$ being employed as a guideline. The ability of a tie to transfer load to the back-up system is a function of the width of the cavity as it relates to buckling of the tie, the connection of the tie to the masonry as it relates to the shear bond strength between the mortar and the unit and the bond between the mortar and the tie, and last but not least, workmanship as it relates to the position of the tie within the wall system and alignment of the tie within the cavity.

For ties attached to the back-up system by means of screws or nails a number of additional factors will contribute to the behaviour and performance of the ties. However, such ties are not examined in this paper.

EXPERIMENTAL PROGRAM MATERIALS

a) Masonry Units

Standard burned clay units, with nominal dimensions of 100 x 67 x 200 mm were used for manufacturing most of the test specimens. The actual size of the wirecut brick unit is 90 x 57 x 190 mm.

The back up systems included 200 x 100 x 400 mm burned clay units or 200 x 200 x 400 mm concrete blocks.

b) Ties

Most of the ties used were commercially available. Most of the ties were manufactured by Blok-Lok, Ltd., a Canadian Company, and consisted of 3.66 mm and 4.76 mm wires (#9 gauge and 5 mm). The most common ties used consisted of two or more parallel side rods with cross rods flush welded at 400 mm o.c. In addition, ties consisting of two or more horizontal rods welded to a continuous diagonal formed cross rod, forming a truss design, were also used. Other ties investigated included Z ties, rectangular ties, and adjustable ties. A number of Z ties were manufactured in the laboratory since they were not readily available.

c) Mortar

Ready mixed, ready-to-use, Type N mortar was used in a large number of the test specimens. For a number of specimens laboratory prepared Type S mortar was employed. The cube strength of the mortar was closely monitored because of its importance in influencing the behaviour of the ties. The actual strength varied from 6.5 to 16.55 MPa.

SPECIMENS

Most of the test specimens were 600 mm long by 400 mm high and they are shown schematically in Figure 1. All specimens were built by an experienced

mason and were cured at least 28 days in a laboratory environment with a temperature of 20° C and a relative humidity of 32%.

In general the ties were placed at the centre of the mortar bedded area. For ties where this was not possible (Type C ties) the location of the rods was the most logical one as shown in Figure 1.

TESTING PROCEDURE

A system consisting of two plates sliding on metal tracks was developed for testing the specimens. The system is shown schematically in Figures 2 and 3.

In a compression test the specimen is placed in the testing machine so that the two wythes rest one on each plate with the plates separated by at least-half the cavity width. Polystyrene back-up padding is placed between the brick wythe and the steel plate as shown in Figure 2. The polystyrene is indented in the vicinity of the tie so that it will not interfere with the mode of failure. A similar indentation is provided on the load application side.

The load is applied by a hydraulic jack whose position is adjustable. Initially the system including the test specimen slides on the lubricated rollers in the metal tracks until the polystyrene back-up is compressed between the bricks and the end plate. The load is then increased gradually until the specimen fails.

In a tension test the brick wythe is held in place as shown in Figure 3 and the other wythe is pulled. Provisions are made to ensure proper load distribution.

TEST RESULTS

Because of the large number of specimens tested only average test results are reported. Table 1 gives a summary of these averages and the dominant failure mode. Typical failure modes are shown in Plates 1, 2, 3 and 4.

Plates 2 and 3 show buckling failures of cross rods in Type D and Type C ties. Plate 4 shows the deformation of the box tie unit in a Type F tie.

Figure 4 shows the relation between mortar compressive strength and failure load for ladder type ties and ladder type with flush welded box ties. The effect of cavity width on the capacity of the system is shown in Figure 5.

The influence of the horizontal leg of the Z tie, (Type H), on its ability to transfer load is evident from the results obtained. The 50 mm Z ties failed at an average load of 2.05 kN and the 25 mm Z ties failed at 0.94 kN.

ANALYSIS OF TEST RESULTS

The capacity of a tie in a push out or pull out action may be defined on the basis of the conditions shown in Figure 6 in which the horizontal rod is assumed to be effective over a length of $3d$ where d is the distance from the rod to the face of the mortar joint. The force required to push out the tie is a function of the shear bond resistance of the effective area, the contribution of friction and the bond between the rod and the mortar.

On the basis of the above, and assuming that buckling is not a problem, the ultimate capacity of the tie may be expressed as

$$P_{ult} = 6Kd^2 [0.15 \sqrt{f_m} + \nu f_c] + \mu 2\pi r \ell \quad (1)$$

where

K = constant related to the diameter of the horizontal rod (1.0 for 3.66 mm rod, 1.25 for 4.76 mm rod)

d = distance from the horizontal rod to the face of the mortar joint

f_m = compressive strength of mortar

f_c = compressive stress due to vertical load at the level considered

ν = coefficient of friction ≈ 0.75

μ = bond strength = $0.15\sqrt{f_m}$

r = rod radius

λ = length of embedment

Neglecting the contribution of friction, Equation 1 reduces to

$$P_{ult} = [0.9Kd^2 + 0.95r\lambda]\sqrt{f_m} \quad (2)$$

The capacity obtained using Equation 2 must be compared with the buckling load of the tie based on cavity width and end conditions.

For Z ties, 1/4 horizontal length of the tie, limited to a maximum of 50 mm, replaces the value of $3d$.

For Type F and Type G rectangular ties, the total horizontal length, with a maximum of $3d$ is used in determining the capacity.

Equation 2 may also be used to determine the tension capacity of a tie. However, for ties in which cross rods are welded to the horizontal rods, the capacity of the weld must also be considered. For 3.66 mm rods, the weld capacity is 1.55 kN.

The largest contribution in Equation 2 results from the shear bond between the mortar and masonry units. Thus the placement of the horizontal rods within the mortar joints should be as accurate as possible in order to achieve the optimum capacity.

For a ladder type tie with one rod in the brick portion of the wall and the other rod in the outer face shell of the block, (Type A), the critical value of d is 1/2 of the shell thickness. For 200 mm block, assuming $d = 25$ mm and $l = 65$ mm, where l includes the length of the cross rod embedded in the inner face shell, and for $K = 1.0$, Equation 2 gives $f_m = 11.0$ MPa and $P_{ult} = 2.01$ kN for $f_m = 7.22$ MPa. These values compare conservatively with the experimental values of 3.08 MPa for $f_m = 11.0$ MPa and 2.11 for $f_m = 7.22$ MPa.

For ties consisting of four horizontal rods, the outer rod is too close to the face of the mortar to be effective. Therefore, $d = 50$ mm for failure in the brick mortar joint. For failure in the block joint, since the distance between the horizontal rods is 139 mm, $d = 1/2 (200-139) = 30.5$ mm and $\lambda = 65$ mm. For $f_m = 16.55$ MPa, $P_{ult} = 4.32$ kN. This compares with an experimental value of 4.83 kN.

Equation 2 applied to rectangular ties provides good agreement with the results obtained. For a tie unit consisting of two horizontal rods with welded rectangular ties, (Type F), the mortar in the block failed at 4.44 kN.

for $f_m = 16.55$ MPa. The overall dimension of this tie system is 266 mm and the tie was placed in the block back-up system at approximately 25 mm from the face. Considering the overall width of the assembly, the distance from the tie to the exterior face of the brick is 22 mm and $\lambda = 67$ mm. From Equation 2,

$P_{ult} = 5.44$ kN for push out failure in the brick. The actual failure was in the block and the failure load of 4.44 kN compares favourably with the failure load of 4.32 kN previously determined for a Type C tie.

From the limited comparison of Equation 2 with the test data it appears that the equation provides a satisfactory prediction for the ultimate capacity of the ties tested.

For design purposes it is suggested that a safety factor of 3.0 be applied to Equation 2. Thus

$$P = [0.30kd^2 + 0.32r\lambda] \sqrt{f_m} \quad (3)$$

based on push-out of the tie.

A complete design procedure must also include checking the capacity of the tie as a compression element or a tension element. In Canadian practice this capacity would be determined on the basis of requirements of CSA S16.1-M78. In computing the load based on buckling considerations, the effective

length used was influenced by the mortar strength with low strength mortar providing little end restraint to tie rotation.

Table 2 compares allowable loads based on Equation 3 and CSA-S16.1-M78, with allowable loads based on a proposed Canadian standard for connectors for masonry, CSA A370-M.

CONCLUSIONS

The system developed to test the performance of ties in cavity walls appears to perform satisfactory.

There is a complex interaction between the shape of tie, the mortar strength, the cavity width and workmanship.

For cavities less than 50 mm the tie capacity increases with increasing mortar strength. For cavities larger than 50 mm buckling of the tie may govern the behavior.

For continuous or box ties the horizontal leg in the brick wythe face should be placed at the centre of the cross section.

For push or pull out failure mode the capacity increases with increased cover on the side opposite the loaded face.

Further testing is required to refine the values suggested for design. REFERENCES

Masonry design and construction for buildings. CSA S304-M78 Canadian

Standards Association, Rexdale, Ontario, Canada, 1978.

Steel structures for buildings - limit states design. CSA S16.1-M78 Canadian

Standards Association, Rexdale, Ontario, Canada, 1978.

Connectors for masonry. Tentative standard CSA A370-M (10th draft) Canadian

Standards Association, Rexdale, Ontario, Canada.

Table 1 SUMMARY OF TEST RESULTS

Tie Type	Type of Load	Cavity Width (mm)	Back-up System	Mortar Strength (MPa)	Average Failure (kN)	Failure Mode	
A	C(1)	25	150 mm CB(3)	16.55	4.40	Mortar in back-up	
		75	"	12.20	2.96	"	
		100	"	16.55	2.77	Buckling of rod	
	T(2)	25	150 mm CB	16.55	3.20	Mortar in back-up	
		25	200 mm B(4)	11.00	3.08	Mortar in block	
	C	25	"	7.22	2.11	Mortar in block	
		75	"	11.00	3.00	Mortar in block	
		140	"	11.00	1.54	Buckling of rod	
	T	75	"	11.00	2.25	Mortar in block	
	D	C	25	200 mm CB	8.00	1.92(5)	Mortar in block
			100	"	8.00	2.19	Buckling of rod
			125	"	8.00	1.52	"
210			"	8.00	1.36	"	
T		100	"	7.90	1.43	Mortar in block	
		100	"	14.00	3.35	"	
		100	"	8.25	2.17	"	
C		25	150 mm CB	12.00	3.65	Mortar in brick	
		150	"	12.00	3.38	"	
		110	200 mm B	11.65	3.12	Buckling of rods	
B		C	75	200 mm B	12.50	3.50	Mortar in brick
			100	"	11.31	2.76	Mortar in brick
	165		"	10.97	1.58	Wire buckled	
	125	150 mm CB	11.00	2.25	Wire buckled		
T	125	150 mm CB	11.00	2.80	Mortar in brick		
C	C	37.5	200 mm B	16.55	4.83	Mortar in block	
		75	200 mm B	16.55	3.28	Buckling of wire	
		150	200 mm B	16.55	1.52	"	
E	C	125	150 mm CB	11.00	2.25	Buckling of wire	
	T	125	150 mm CB	11.00	2.80	Mortar in brick	
F	C	50	200 mm B	16.55	4.44	Mortar in block	
		90	200 mm B	13.50	2.87	"	
		140	200 mm B	8.50	1.79	"	
		25	200 mm B	8.28	1.31(6)	"	
		140	200 mm B	8.28	0.90(6)	"	
H	C	50	150 mm CB	11.00	2.19	Mortar in block	
		50	200 mm B	11.00	1.96	"	
		100	200 mm B	11.00	2.01	"	
		50	200 mm B	7.70	0.88	"	
		100	200 mm B	7.70	1.00	"	
	T	50	200 mm B	7.70	1.41	Mortar in block	
		50	200 mm B	6.45	0.57(6)	Mortar in brick	
		100	200 mm B	6.45	0.84(6)	"	
G	C	100	200 mm B	11.00	4.37	Mortar in brick	
		100	200 mm B	7.50	3.18	"	
		150	150 mm CB	14.80	4.36	"	
	T	150	150 mm CB	6.80	2.28	Mortar in brick	

- (1) Compression
- (2) Tension
- (3) Concrete block
- (4) Brick
- (5) Failure load for 2 rods
- (6) 4.76 mm rod
- (7) For Type H ties the horizontal leg is 50 mm in length for 3.66 mm rods and 25 mm for 4.76 mm rods

Table 2 RECOMMENDED ALLOWABLE LOADS PER TIE

Tie Type	Cavity (mm)	Mortar Type	Allowable Load			
			Equation 3 Compression (kN)	Equation 3 Tension (kN)	CSA A370-M Compression (kN)	CSA A370-M Tension (kN)
A	50	M	1.50	1.00	0.675	0.675
		S	1.00	.75		
		N	.75	.50		
	75	M	1.25	1.00	0.675	0.675
		S	.75	.75		
		N	.50	.50		
	100-150	M	1.00	1.00	0.375	0.675
		S	.75	.75		
		N	.50	.50		
D	50	M	1.75	1.25	0.675	0.675
		S	1.25	1.00		
		N	1.00	0.75		
	75	M	1.50	1.25	0.675	0.675
		S	1.00	1.00		
		N	.75	.75		
	100-150	M	1.25	1.25	0.375	0.675
		S	0.75	1.00		
		N	0.50	0.75		
B,C,E	50	M	1.75	1.75		
		S	1.50	1.50		
		N	1.00	1.00		
	75	M	1.50	1.75		
		S	1.00	1.50		
		N	0.75	1.00		
	100-150	M	1.25	1.75		
		S	0.75	1.50		
		N	0.50	1.00		
F,G	50	M	1.65	1.65	1.60	1.60
		S	1.40	1.40		
		N	0.90	0.90		
	75	M	1.40	1.65	1.60	1.60
		S	0.90	1.40		
		N	0.65	0.90		
	100-150	M	1.15	1.65	1.60	1.60
		S	0.65	1.40		
		N	0.50	0.90		
H*	50	M	0.75	0.75	0.800	0.800
		S	0.50	0.50		
		N	0.25	0.25		
	75	M	0.75	0.75	0.800	0.800
		S	0.50	0.50		
		N	0.25	0.25		
	100-150	M	0.75	0.75	0.800	0.800
		S	0.50	0.50		
		N	0.25	0.25		

* Increase allowable loads based on Equation 3 by 0.25 kN if tie is grouted in the cores of the concrete block.

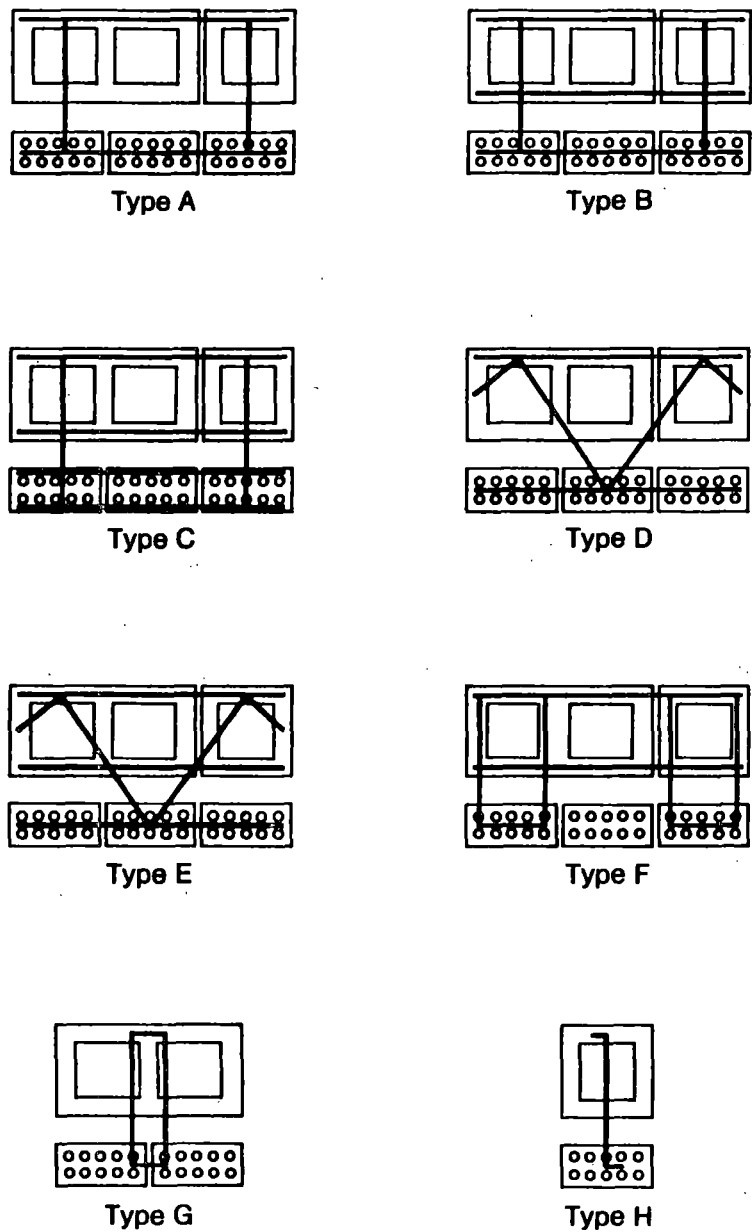

FIGURE 1. TEST SPECIMENS.

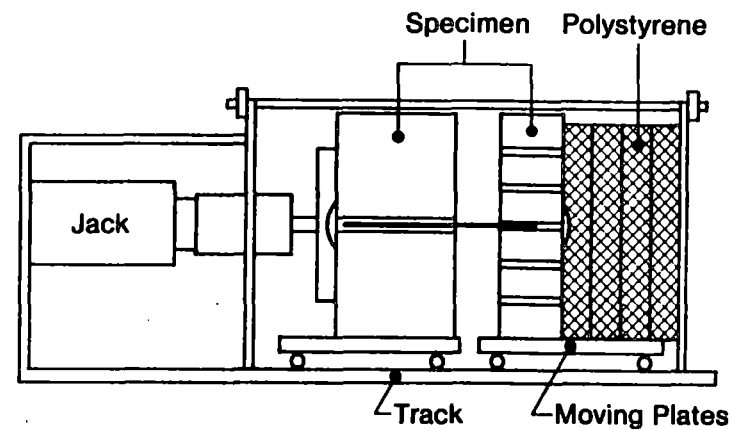

FIGURE 2. SCHEMATIC REPRESENTATION OF TESTING SYSTEM OF COMPRESSION.

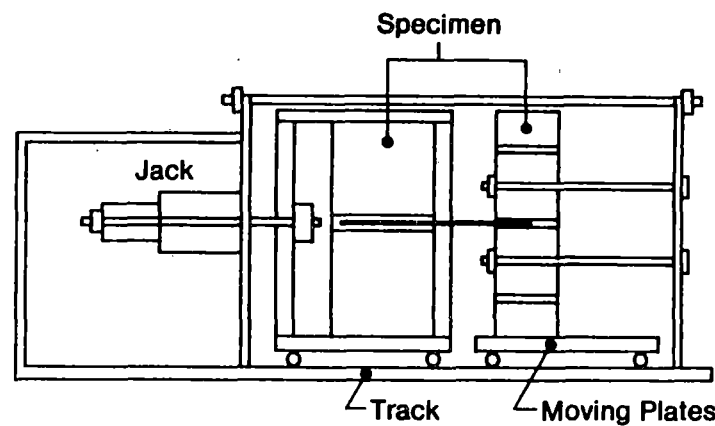

FIGURE 3. SCHEMATIC REPRESENTATION OF TENSION TEST.

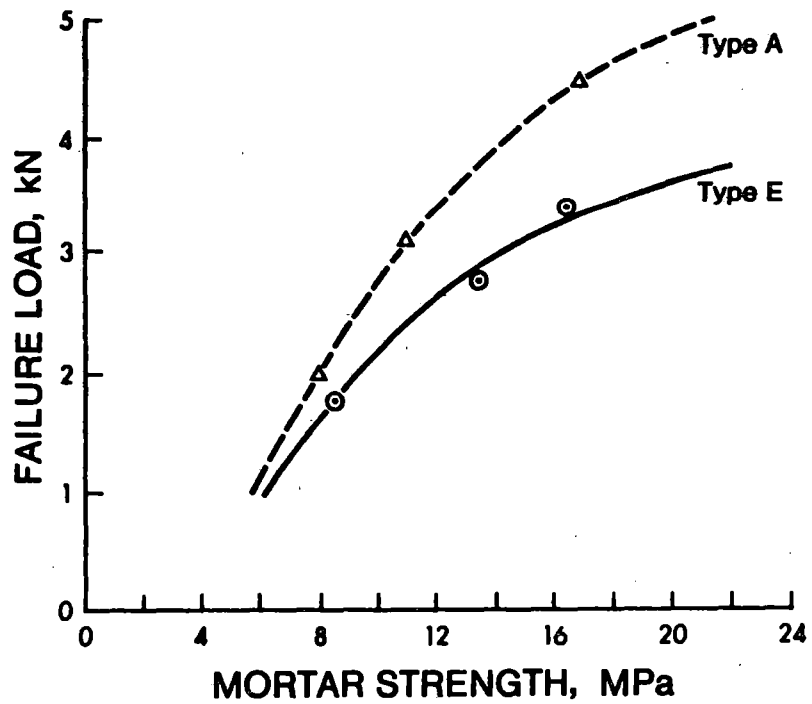

FIGURE 4. RELATION BETWEEN MORTAR COMPRESSIVE STRENGTH AND FAILURE LOAD.

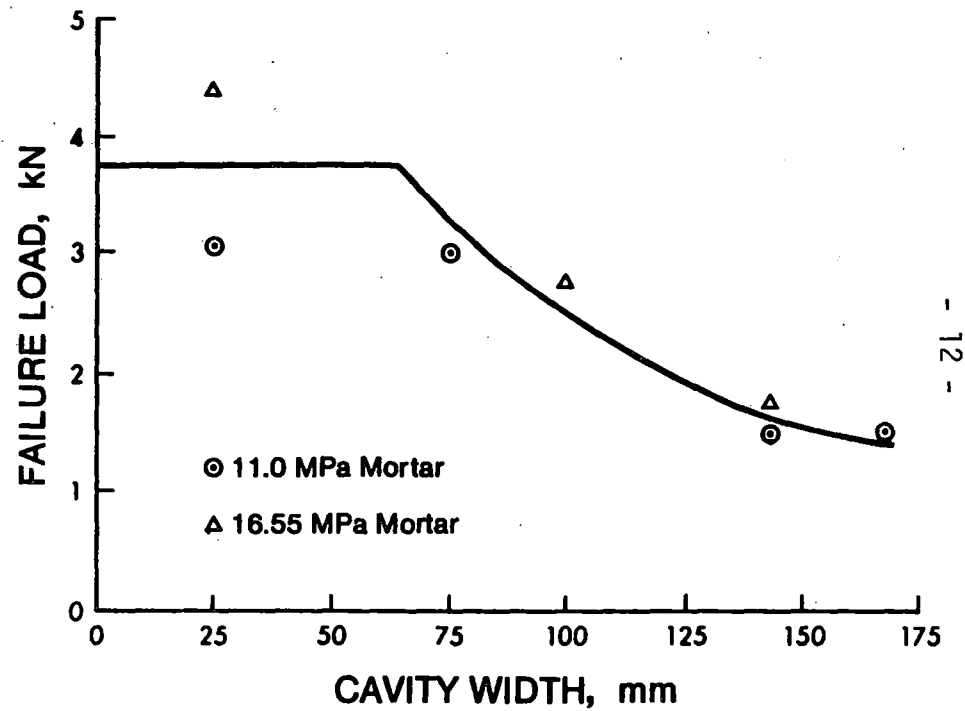

FIGURE 5. EFFECT OF CAVITY WIDTH ON TIE CAPACITY FOR 3.66 mm LADDER TYPE TIES.

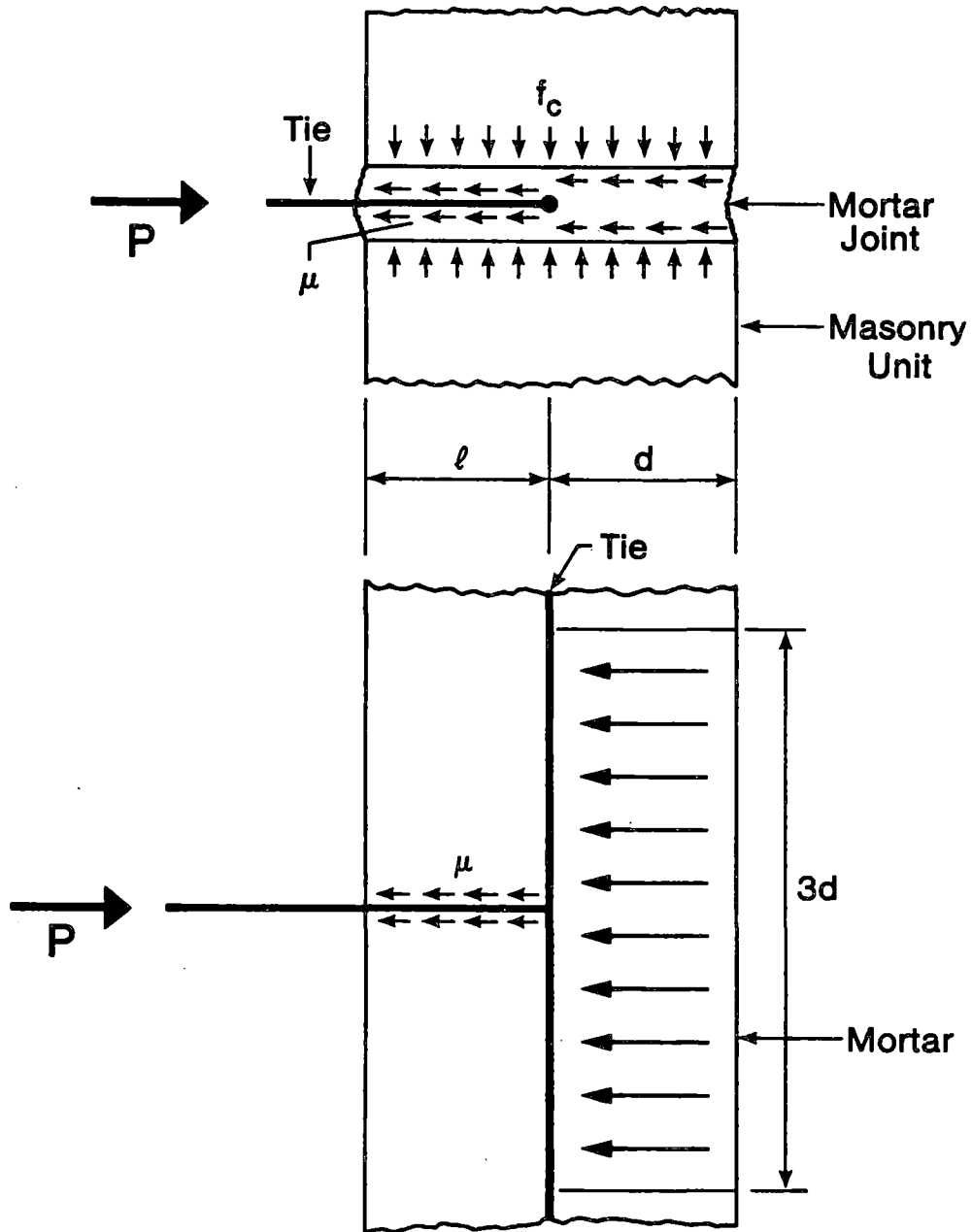

FIGURE 6. FORCES RESISTING PUSH-OUT FORCE.

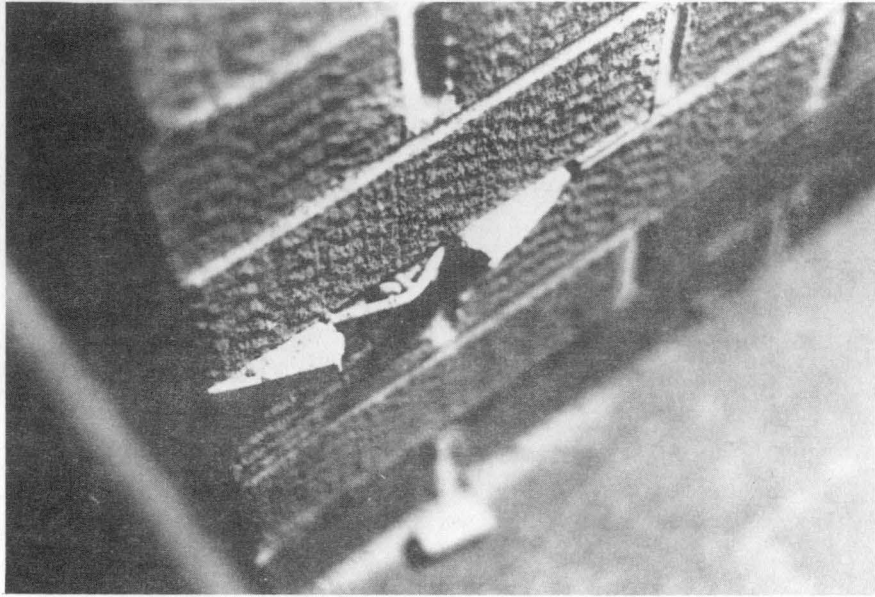

Plate 1. Deformation of Type B Tie

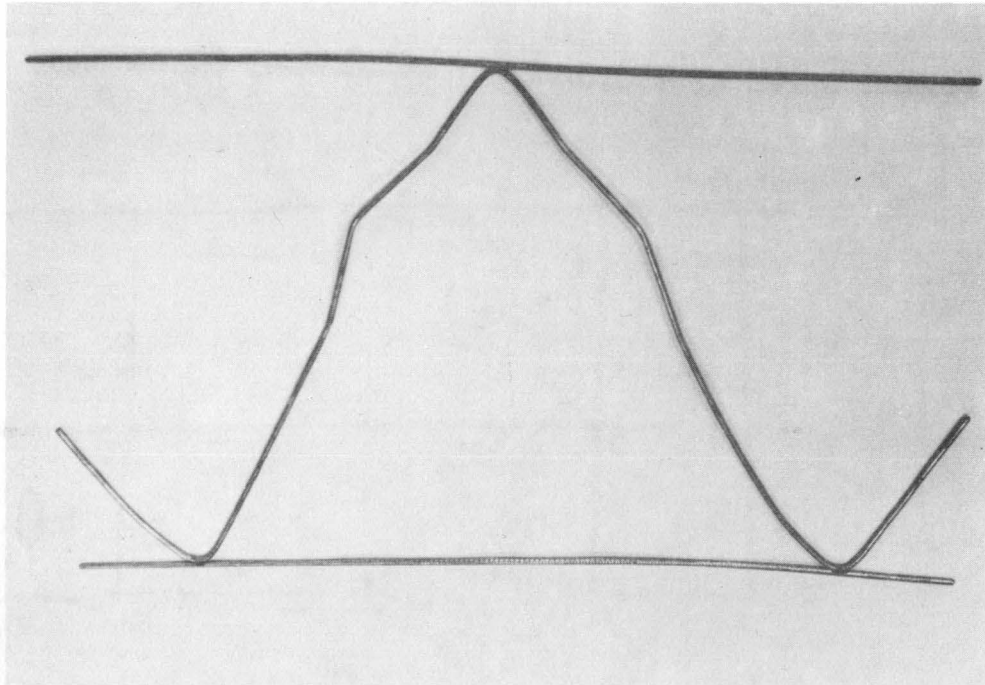

Plate 2. Buckling of Type D Tie

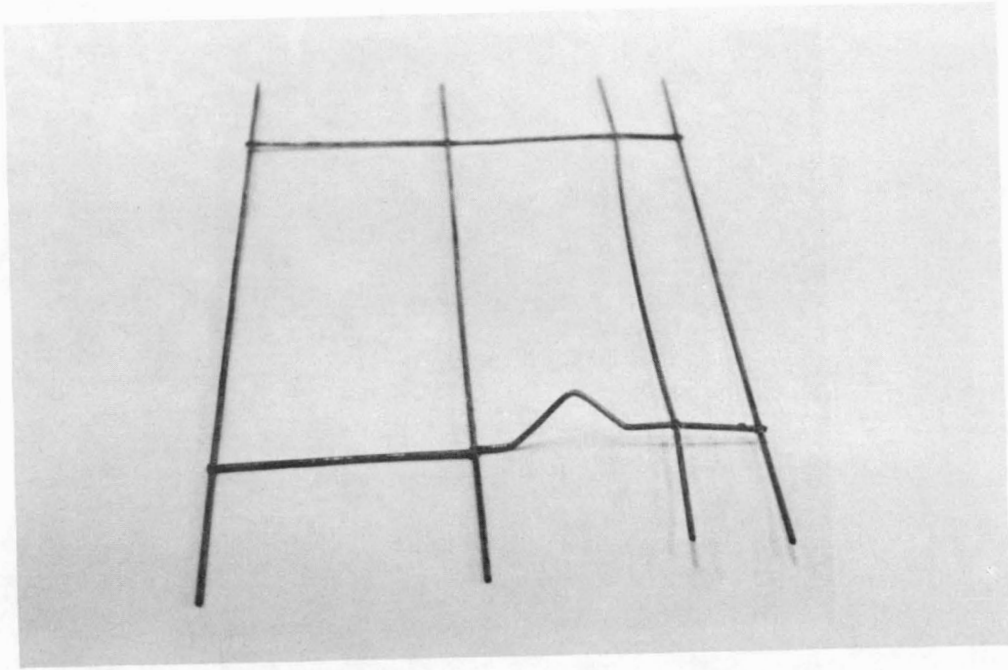

Plate 3. Buckling of Type C Tie

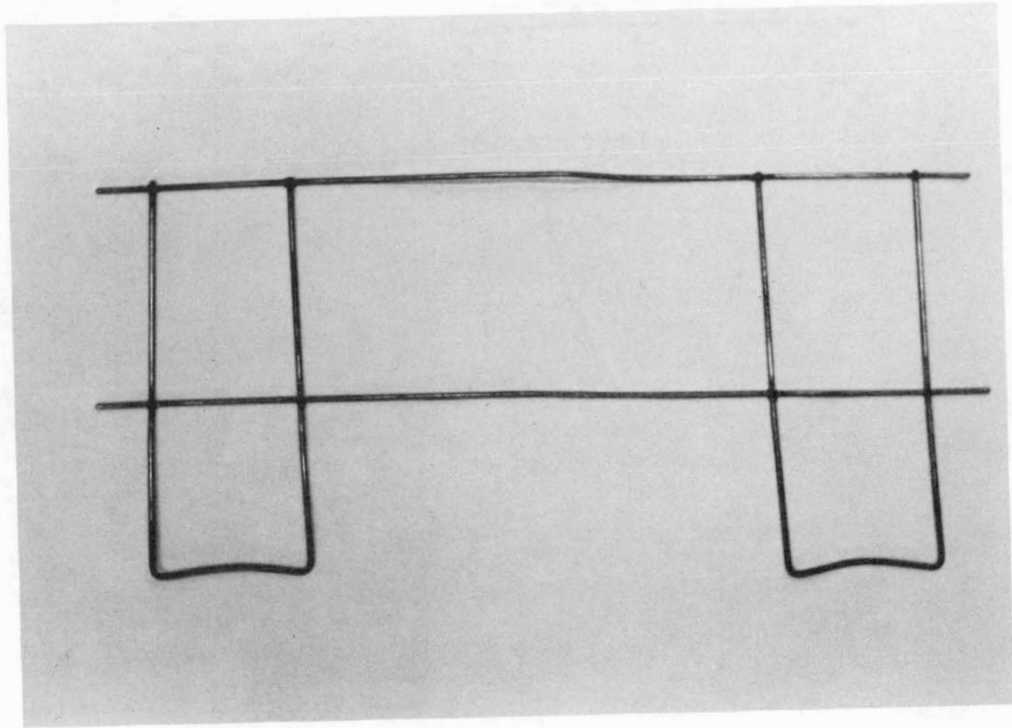

Plate 4. Deformation of Type F Tie